

國立成功大學

115學年度碩士班招生考試試題

編 號： 90

系 所： 工程科學系

科 目： 資料結構

日 期： 0204

節 次： 第 1 節

注 意： 1. 不可使用計算機
2. 請於答案卷(卡)作答，於
試題上作答，不予計分。

1. (20%) Consider the following pseudocode:

```

Z = n
for x = 1 to n do
    for i = 1 to x do
        for j = 1 to x do
            if (i != j) then
                Z++;
            end if
        end
    end
end
end
end
    
```

Assume that n is a positive integer and that the variable Z is **initially set to n** .

The statement $Z++$ increases the value of Z by 1 each time it is executed.

Question:

Using n as the variable, determine the **final value of Z** after the algorithm terminates.

Your answer should be expressed as a **closed-form formula** in terms of n .

2. (20%) Consider a discrete memoryless source that emits the following symbols with **distinct, positive frequencies**:

Symbol	A	B	C	D	E	F
Frequency	4	7	10	15	20	45

(a). (10%) Compute the **Weighted Path Length (WPL)** of the resulting Huffman Tree..

(b). (10%) Let L_{avg} denote the average codeword length of the Huffman code. Compute L_{avg} and **round your answer to three decimal places..**

3. (20%) Consider the following list of distinct integers:

[50,30,70,20,40,60,80]

The list represents the order in which elements are **inserted into an initially empty Binary Search Tree (BST)** using the standard BST insertion rule.

(a). (5%) Please construct a Binary Search Tree from the list.

(b). (15%) What are the pre-order, in-order, and post-order traversals of your tree for Question (a)? Please write down the sequences of the numbers.

4. (20%) Consider the following sorting algorithms:

- Bubble Sort
- Selection Sort
- Insertion Sort
- Merge Sort
- Quick Sort
- Heap Sort

(a). (12%) Indicate **which of the above sorting algorithms are unstable**.

(b). (8%) Among the sorting algorithms identified as unstable in part (a), indicate the algorithm(s) that have the best worst-case time complexity.

5. (20%) Consider the following **directed weighted graph** with vertices.

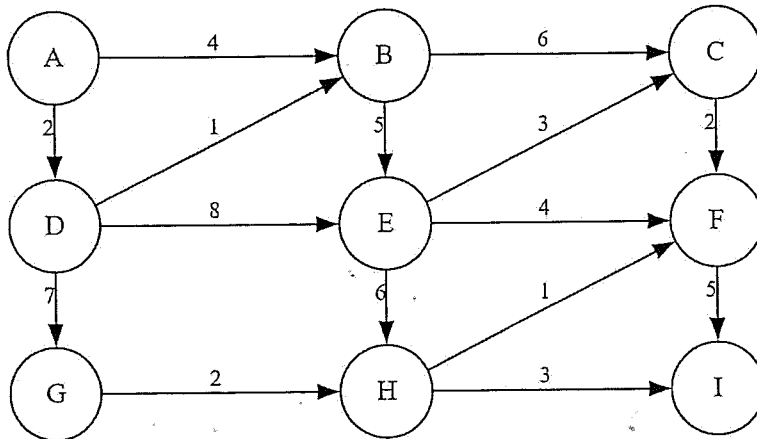

(a). (5%) Determine the **shortest path from vertex A to vertex H**.

(b). (15%) Based on your answer in part (a), determine the **total cost (sum of edge weights)** of the shortest path.