

# 國立成功大學

## 115學年度碩士班招生考試試題

編 號：83

系 所：工程科學系

科 目：工程力學

日 期：0204

節 次：第 1 節

注 意：1. 可使用計算機  
2. 請於答案卷(卡)作答，於  
試題上作答，不予計分。

※工程力學共有八題，請詳細條列計算或誘導過程。請考生將每題的答案（若有單位請包含單位）以方框標註出來，以利批改考卷。

1. (5%) Determine the total surface area of a right circular cylinder with a radius of 2.5 cm and a height of 1.5 cm.
2. (5%) Suppose  $A = B^p C^q$ , where  $A$  has dimensions  $L^2 T^2$ ,  $B$  has dimensions  $L^4 T^{-2}$ , and  $C$  has dimensions  $L^2 T^4$ . Determine the values of exponents  $p$  and  $q$ .
3. (5%) The coordinate of a particle in meters is given by  $x(t) = 24t - 4t^3$ , where the time  $t$  is in seconds. The particle is momentarily at rest at  $t = ?$
4. (5%) Let  $\vec{S} = (1m)\hat{i} + (2m)\hat{j} + (2m)\hat{k}$  and  $\vec{T} = (5m)\hat{i} + (12m)\hat{k}$ . Determine the angle between these two vectors.
5. (25%) A rectangular plate is supported by three cables as shown. Knowing that the tension in cable  $AD$  is 390N, determine the weight of the plate. (Dimensions in mm)

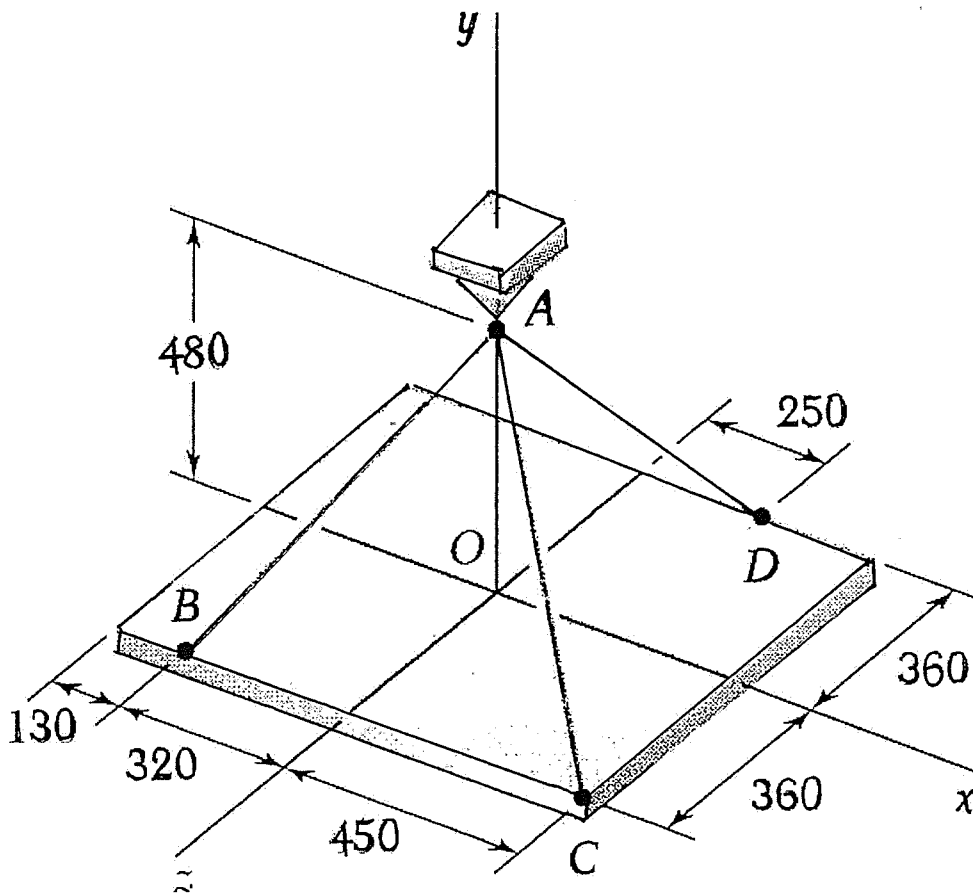

6. (15%) Knowing that the coefficient of friction between the 30-kg block and the incline is  $\mu_s = 0.25$ , determine (a) the smallest value of  $P$  required to start the block moving up the incline, (b) the corresponding value of  $\theta$ .

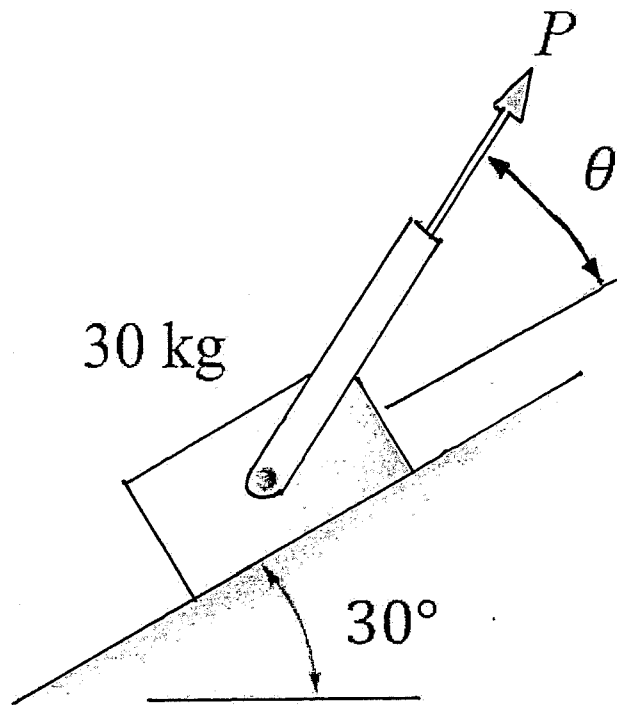

7. (20%) A volleyball player serves the ball with an initial velocity  $v_0$  of magnitude 14 m/s at an angle of  $20^\circ$  with the horizontal. Determine (a) if the ball will clear the top of the net, (b) how far from the net the ball will land.

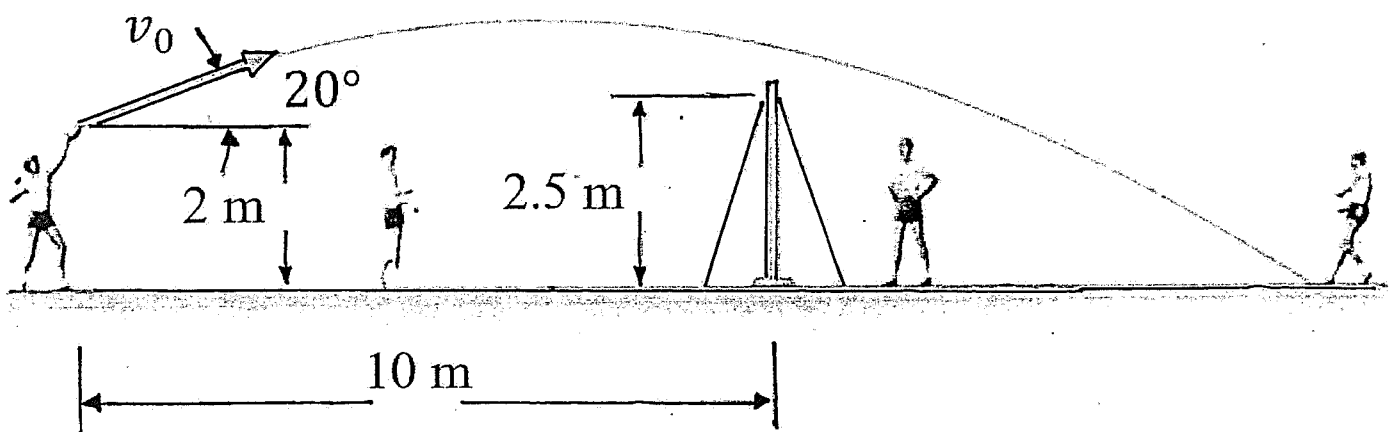

8. (20%) Two identical blocks are released from rest. Neglecting the mass of the pulleys and the effect of friction, determine the velocity of Block B after it has moved 1 m.

