

力 學

1. Determine the force in member EB produced by the action of the applied couple on the space frame. Also compute the components of force acting on CD at D. Point E is midway between C and D, and connections A, B, C, D, and E may be treated as ball-and-socket joints. (25%)

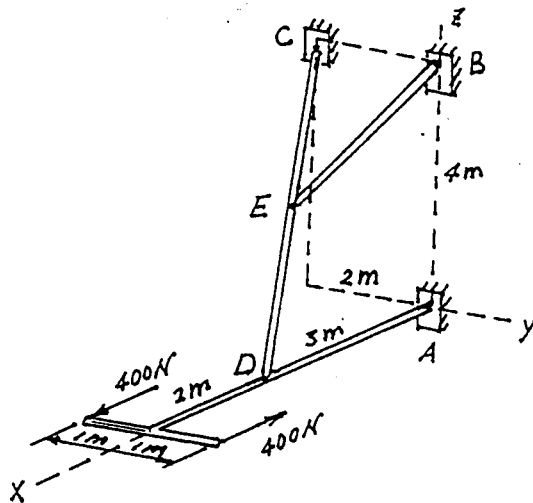

Problem 2 In Fig. 2, XY coordinate is an inertial frame. A man sits inside a vehicle which is travelling with constant angular velocity Ω counterclockwise in a circle with center O and radius r . However, he does not know that he is moving and he knows nothing but the coordinate xy which is fixed in the vehicle. Let Point P be moving with constant velocity V in the positive X direction. For the position given, what is the velocity and acceleration of Point P from the man's point of view? (25%)

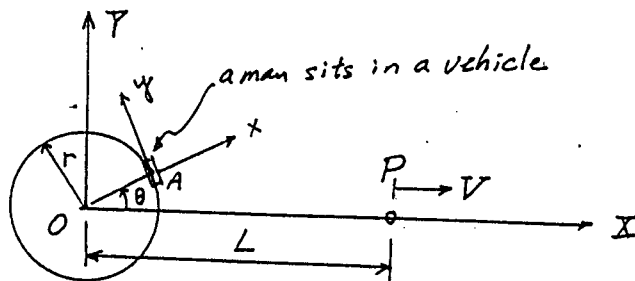
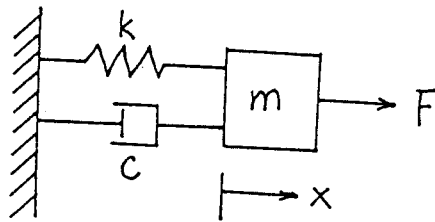

Fig. 2

3. Consider the following system with x being the elongation of spring k .



- Derive the governing equation of this system. (5%)
- What are the natural frequency and damping ratio of this system? (5%)
- Suppose $F(t) = 0$, and x_0, V_0 are initial position and velocity of m , respectively. Solve $x(t)$. (5%)
- Suppose the system is subjected to a unit impulse force at $t = 1$, i.e., $F(t) = \delta(t - 1)$, from its rest and unstretched position. Solve $x(t)$.
(Hint: $\int_0^{\infty} \delta(t) dt = 1$) (10%)

Problem 4 The spring-damper-mass system shown in Fig. 4 is driven with force F .

- Derive the equations of motion. (15%)
- If $k \rightarrow \infty$, what do the equations of motion become? (10%)

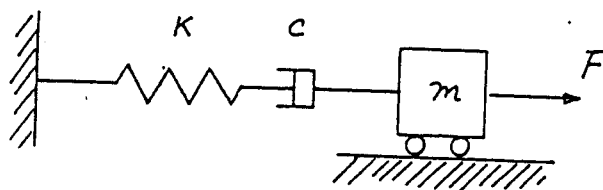

Fig. 4