

系所組別：電機工程學系甲乙丁戊組、電腦與通信工程研究所丙丁組、電機資訊學院-微電奈米聯招

考試科目：電子學

考試日期：0222，節次：1

※ 考生請注意：本試題可使用計算機。請於答案卷(卡)作答，於本試題紙上作答者，不予計分。

1. Fig. 1 shows a circuit that performs the high-pass transfer function.
 - (1) Derive the transfer function of this circuit and identify its high-frequency gain and 3-dB frequency. (4%)
 - (2) Determine the values of R_1 , R_2 , and C to obtain a high-frequency input resistance of 10 k Ω , a high-frequency gain of 40 dB, and a 3-dB frequency of 1000 Hz. (6%)
 - (3) At what frequency does the magnitude of the transfer function reduce to unity? (4%)

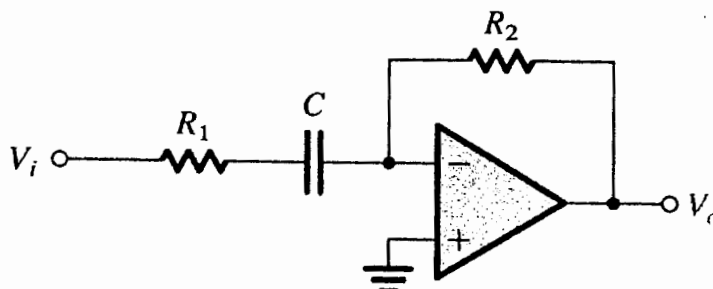

Fig. 1

2. It is required to design the active-loaded differential MOS amplifier of Fig. 2 to obtain a differential gain of 50 V/V. The technology available provides $\mu_n C_{ox} = 4\mu_P C_{ox} = 400 \mu\text{A}/\text{V}^2$, $|V_t| = 0.5 \text{ V}$, and $|V_A'| = 20\text{V}/\mu\text{m}$ (channel length modulation effect) and $V_{DD} = V_{SS} = 1\text{V}$. Use a bias current $I = 200\mu\text{A}$ and operate all devices at $|V_{OV}| = 0.2\text{V}$ (overdrive voltage).
 - (1) Find the W/L ratios of the four transistors (Q_1 , Q_2 , Q_3 , and Q_4). (4%)
 - (2) Specify the channel length required of all transistors. (4%)
 - (3) If I is delivered by a simple NMOS current source operated at the same V_{OV} , for $V_{CM} = 0$, what is the allowable range of v_o ? (4%)

(背面仍有題目,請繼續作答)

系所組別：電機工程學系甲乙丁戊組、電腦與通信工程研究所丙丁組、電機資訊學院-微電奈米聯招

考試科目：電子學

考試日期：0222，節次：1

※ 考生請注意：本試題可使用計算機。請於答案卷(卡)作答，於本試題紙上作答者，不予計分。

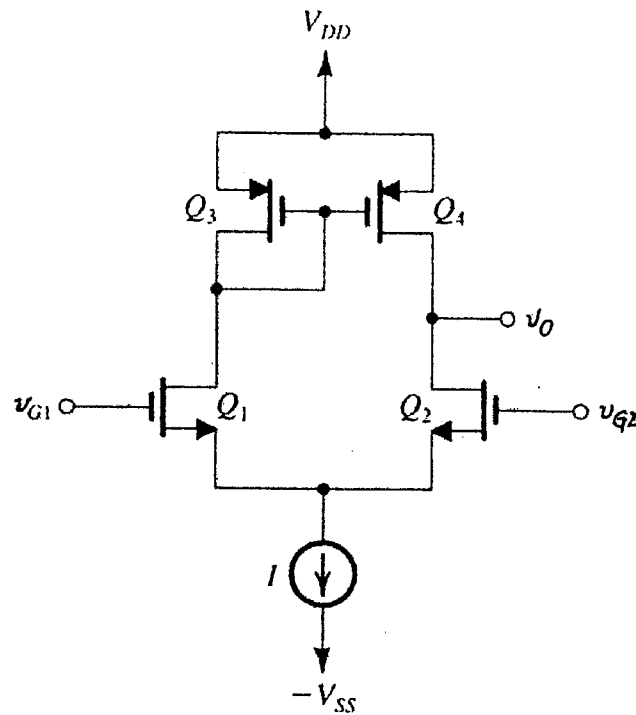

Fig. 2

3. The open-loop gain of an amplifier has break frequencies at $f_{p1}=100$ kHz, $f_{p2}=200$ kHz, and $f_{p3}=1$ MHz. The low-frequency (or DC) gain is $A_o=800$, and the feedback factor is $\beta=0.5$. Please calculate
 - (1) The gain crossover frequency. (4%)
 - (2) The phase margin. (4%)

4. An amplifier with open-loop voltage gain of 10^4 and poles at 10^3 Hz, 10^5 Hz, and 10^6 Hz is to be compensated by the addition of a dominant pole to operate stably with a closed-loop gain of 30 dB with a 45° phase margin, what new pole frequency should be used? (6%)

※ 考生請注意：本試題可使用計算機。請於答案卷(卡)作答，於本試題紙上作答者，不予計分。

5. (1) A second-order filter has the transfer function

$$T(S) = \frac{1}{S^2 + (10 + \alpha)S + 25}$$

Find the range of α for which the filter can operate stably? (4%)

- (2) What type of this filter can be realized as the following transfer function?

Explain why? (8%)

$$T(S) = \frac{S(S^2 + 0.01)(S^2 + 4)}{(S^2 + 0.8S + 0.52)(S^2 + 0.56S + 0.18)(S^2 + 0.56S + 0.86)}$$

6. A waveform generator circuit is shown in Fig. 6. If the op amps have saturation voltages of ± 10 V, given $C = 0.01$ m F, $R_1 = 10$ k Ω , $R_2 = 20$ k Ω , and $R = 50$ k Ω .

- (1) Sketch and label the waveforms v_1 and v_2 . (10%)
 (2) Determine the frequency of waveform v_1 . (5%)

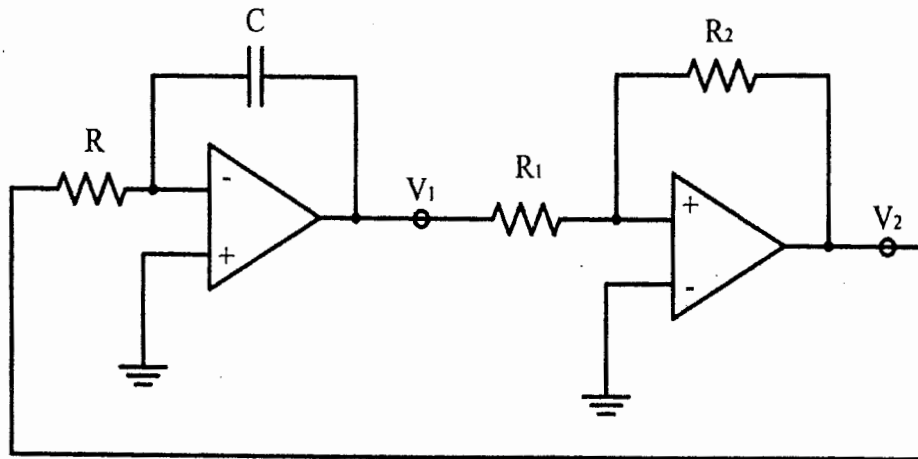

Fig. 6

7. Consider the circuit shown in Fig. 7 with parameters of $v_i = 5 \times \sin(\omega t)$ volts where $\omega = 2000\pi$ radians/sec, $C_1 = C_2 = 1\mu$ F and uncharged initially, the cut-in voltage of both diodes V_f while the forward diode resistance $r_f = 0\Omega$, reverse breakdown voltage = 100 V, saturation current = 2.5×10^{-9} A.

(背面仍有題目,請繼續作答)

※ 考生請注意: 本試題可使用計算機。請於答案卷(卡)作答, 於本試題紙上作答者, 不予計分。

(1) What are the maximum and minimum voltage of v_o when $V_y = 0$ for Fig. 7(a)?

(4%)

(2) Assume $V_y = 0$ for Fig. 7(a). Sketch waveforms of v_{C1} and v_o along with

v_I starting from $t = 0$ sec to 3 ms. (10%)

(3) Assume $V_y = 0.7$ V for Fig. 7(b). What are the maximum and minimum voltage

of v_o ? (4%)

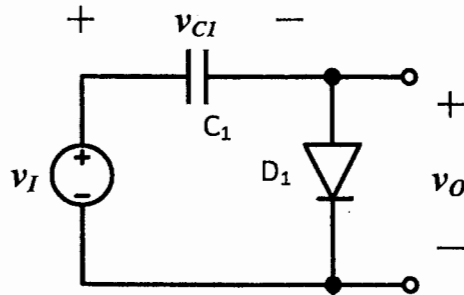

(a)

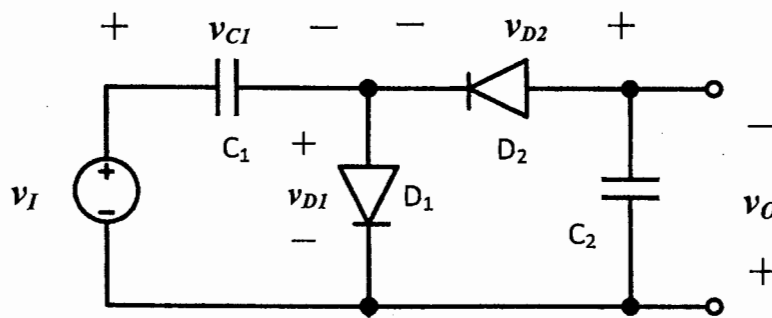

(b)

Fig. 7

※ 考生請注意：本試題可使用計算機。請於答案卷(卡)作答，於本試題紙上作答者，不予計分。

8. Consider the circuit shown in Fig. 8 with parameters of $V_{DD}=5\text{ V}$, $\mu_n C_{ox}=40\ \mu\text{ A/V}^2$, and $\mu_p C_{ox}=20\ \mu\text{ A/V}^2$, $V_{tn}=|V_{tp}|=1\text{ V}$, $(W/L)_{Q1}=(W/L)_{Q3}=2\ \mu\text{ m}/1\ \mu\text{ m}$, $(W/L)_{Q2}=(W/L)_{Q4}=4 \times (W/L)_{Q1}$, $(W/L)_{Q5}=(W/L)_{Q6}=(W/L)_{Q7}=(W/L)_{Q8}$. Note that B and \bar{B} are outputs while Set , $Reset$, and Clk are inputs. Clk is the clock signal. Set and $Reset$ are complementary signals, i.e., when $Set = V_{DD}$, $Reset = 0$; vice versa.

- (1) Determine the minimum W/L for both Q_5 and Q_6 required to ensure that the two back-to-back inverters of the circuit will switch at half of V_{DD} when inputs Set and Clk are V_{DD} . (7%)
- (2) Find the minimum W/L for both Q_5 and Q_6 such that switching is achieved when inputs Set and Clk are half of V_{DD} . (8%)

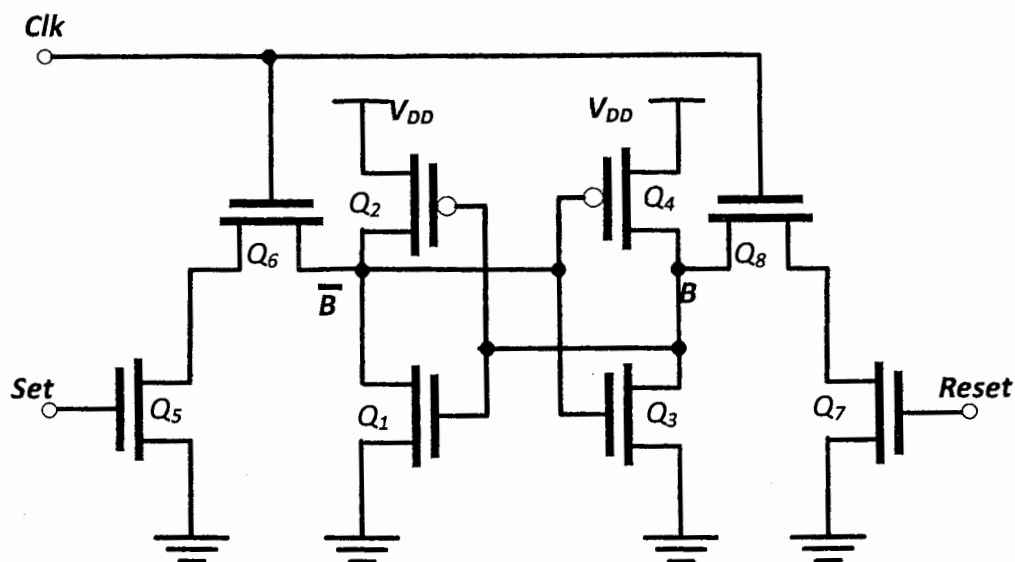

Fig. 8