

※ 考生請注意：本試題可使用計算機。請於答案卷(卡)作答，於本試題紙上作答者，不予計分。

1. In the circuit shown in Fig. 1, both diodes are identical, conducting 10 mA at 0.7 V and 100 mA at 0.8 V. For  $V_O = 80$  mV, find the value of R. Given the thermal voltage  $V_T = 25$  mV. (10%)

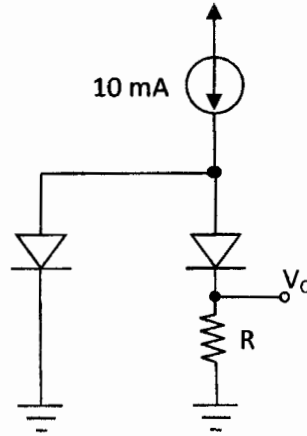

Fig. 1

2. In the circuit shown in Fig. 2,  $v_{sig}$  is a small sinewave signal with zero average. Given the transistor  $\beta = 100$ ,  $r_o = 200$  k $\Omega$ , and  $R_C = 20$  k $\Omega$ .

- (a) Find  $R_E$  for a dc emitter current of 0.5 mA. (5%)  
 (b) Find the (small-signal) voltage gain. (8%)

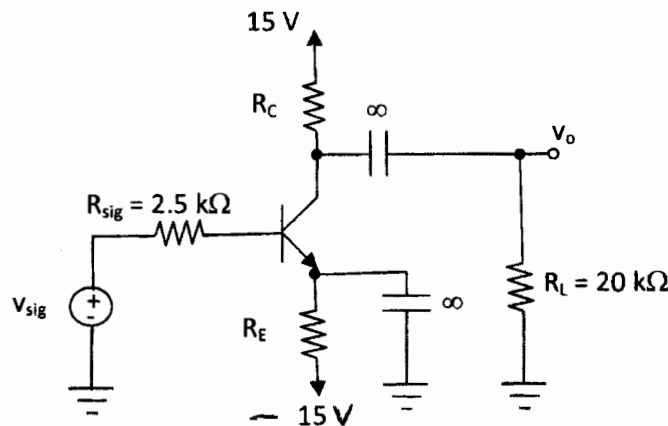

Fig. 2

3. In the circuit shown in Fig. 3, the two transistors have equal lengths ( $L_1 = L_2$ ) but widths related by  $W_2/W_1 = 5$ . Design the circuit to obtain  $I_O = 0.5$  mA. Let  $k_n'(W/L)_1 = 0.8$  mA/V<sup>2</sup>,  $V_t = 1$  V, and  $\lambda = 0$ .

- (a) Find the required value of R. (5%)  
 (b) What is the lowest possible  $V_O$  while  $Q_2$  remains in the saturation region? (5%)

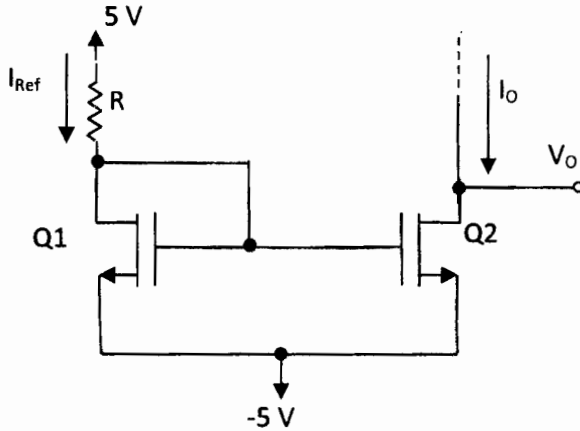

Fig. 3

4. Fig. 4 show a series-shunt amplifier in which the three MOSFETs are sized to operate at  $|V_{OV}|=0.2$  V. Let  $|V_t|=0.5$  V,  $|V_A|=20$  V,  $I=0.1$  mA,  $R_1=2$  k $\Omega$ , and  $R_2=18$  k $\Omega$ . The current sources utilize single transistors and thus have output resistances equal to  $r_o$ .
- Calculate the overall open-loop voltage gain  $A$ . (4%)
  - Find feedback factor  $\beta$ . (3%)
  - Find closed-loop gain  $A_f=V_o/V_s$ . (3%)
  - Find the output resistance  $R_{out}$ . (3%)

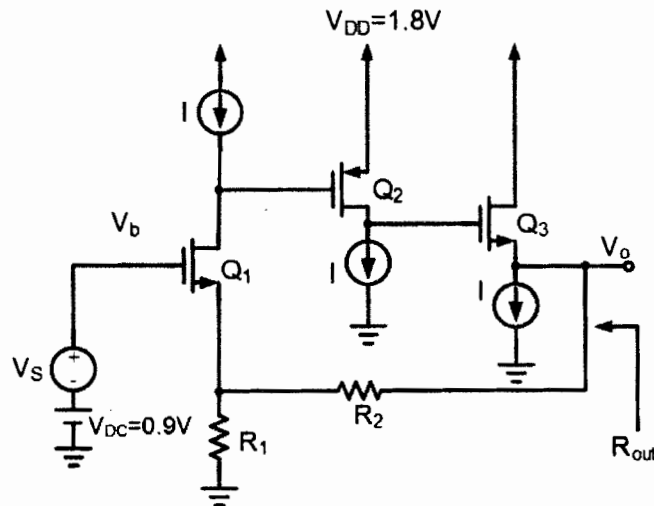

Fig. 4

5. For the cascoded gain stage in Fig. 5, let  $2I=26$   $\mu$ A;  $\mu_n C_{ox}=20$   $\mu$ A/V<sup>2</sup>;  $\mu_p C_{ox}=10$   $\mu$ A/V<sup>2</sup>;  $|V_t|=1$  V;  $|V_A|=26$  V;  $W/L$  for  $Q_1$ ,  $Q_2$ ,  $Q_{1C}$ , and  $Q_{2C}=130/8$ ;  $W/L$  for  $Q_{3C}$  and  $Q_{4C}=65/8$ ; and  $W/L=8/8$  for  $Q_3$  and  $Q_4$ .
- Find output impedance,  $R_o$  (5%)
  - Find voltage gain,  $A=V_o/(V_{in^+}-V_{in^-})$  (5%)

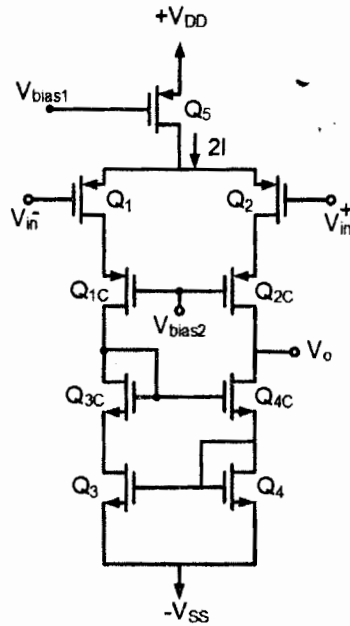

Fig. 5

6. The NMOS transistor in the discrete CS amplifier circuit of Fig. 6 is biased to have  $g_m=1\text{mA/V}$ , Find the three poles ( $\omega_{p1}$ ,  $\omega_{p2}$ ,  $\omega_{p3}$ ) relative to  $0.01\mu\text{F}$ ,  $0.1\mu\text{F}$ ,  $10\mu\text{F}$  and the gain ( $A_M$ ) in the transfer function of

$$\frac{V_o}{V_{sig}} = A_M \left( \frac{s}{s + \omega_{p1}} \right) \left( \frac{s}{s + \omega_{p2}} \right) \left( \frac{s}{s + \omega_{p3}} \right) \quad \text{where } \omega_{p_i} = 2\pi f_i$$

(10%)

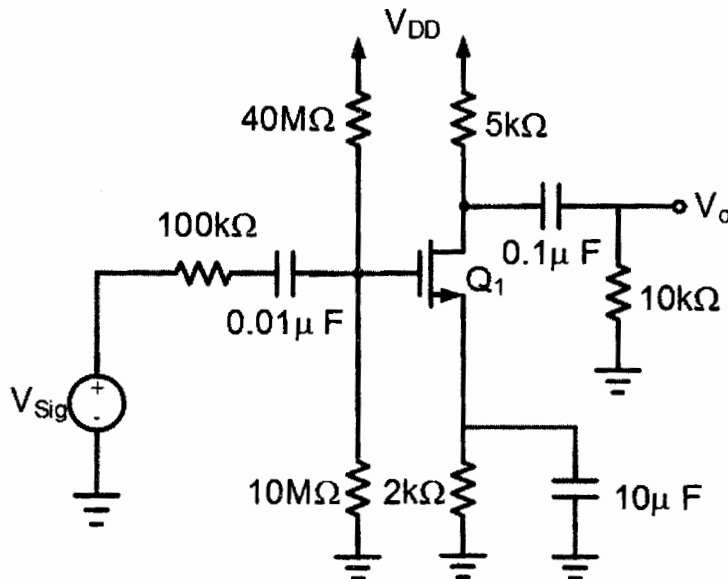

Fig. 6

7. For the circuit shown in Fig. 7, assuming the threshold voltages of all transistors to be equal in magnitude and  $k_1=k_2, k_3=k_4=16k_1$ . (Note that  $k = \frac{1}{2}\mu_{ox} \frac{W}{L}$ ). Find the required value of  $I_1$  to yield a bias current in  $Q_3$  and  $Q_4$  of 1.6 mA. (6%)

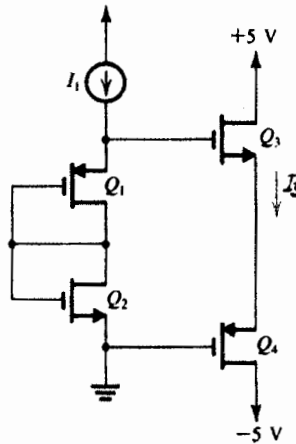

Fig. 7

8. For the circuit shown in Fig. 8, assuming that the op amplifier is ideal.
- Derive the expression of voltage transfer ratio  $\frac{v_o}{v_s}$  as a function of  $\omega$ . (4%)
  - Sketch the magnitude Bode plot to scale. (4%)
  - For design requirements of DC gain=2 and cutoff frequency= 500Hz, find the values of  $R_2$  and  $C$ , assume  $R_1=1 \text{ k}\Omega$ . (4%)

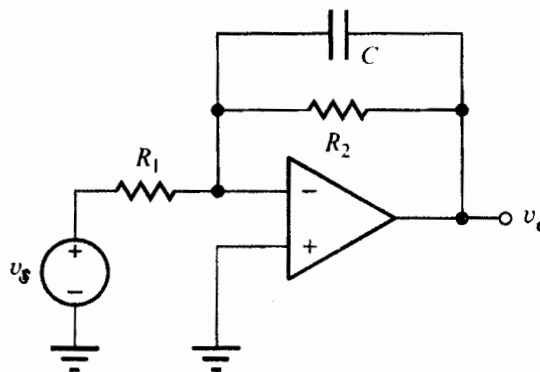

Fig. 8

9. Consider the circuit illustrated in Fig. 9.
- Find the minimum value of  $R_2/R_1$  required for oscillation. (4%)
  - Find the frequency of oscillation. (4%)

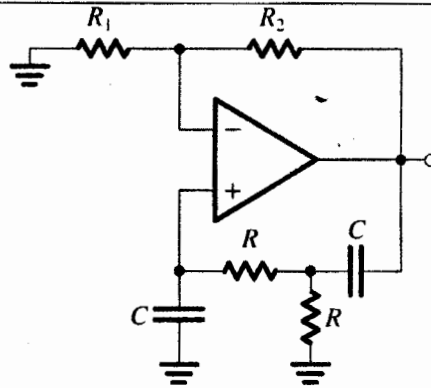

Fig. 9

10. Fig. 10 shows a circuit that performs signal generation.

- (a) Draw the waveforms of  $v$  and  $v_o$ . (4%)
- (b) What is its frequency of oscillation? (4%)

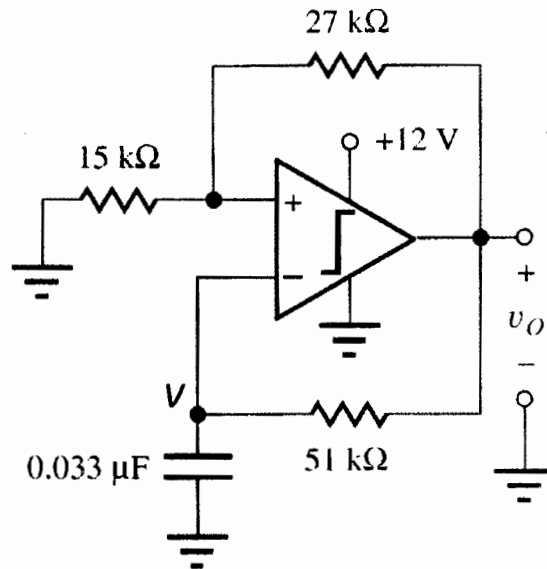

Fig. 10