

1. As the circuit shown in Fig.1, let $\beta=100$, $C_i=2\text{pF}$ and $f_T=400\text{MHz}$. Calculate the midband gain and the upper 3-dB frequency. (12%)
2. A multiple amplifier having a first pole at 1MHz and an open-loop gain of 100dB is to be compensated for closed-loop gains as low as 20 dB by introduction of a new dominant pole. At what frequency must the new pole be placed?(3%)
3. Consider the complementary BJT class B output stage and neglect the effects of V_{BE} and V_{CEsat} . For $\pm 10\text{V}$ power supplies and a $100\text{-}\Omega$ load resistance, what is the maximum sine-wave output power available? What supply power corresponds? What is the power-conversion efficiency? For output signals of half this amplitude, find the power-conversion efficiency.(10%)
4. Draw and explain briefly the possible load line of an enhancement-mode n-MOSFET using (a) a forward-biased diode, or (b) a reverse-biased diode, or (c) a depletion-mode n-MOSFET with $V_{GS} = 0\text{V}$ as the load device. (15%)
5. Calculate the small-signal input resistance R_i as shown in Fig. 2. Assume $R_B = R_C = 2\text{ k}\Omega$, $g_m = 25\text{ mS}$, $\beta = 100$, and $r_o = \infty$. (10%)
6. (a) A CMOS inverter pair is shown in Fig. 3(a). Let $V_{TN}=0.8\text{V}$, $V_{TP}=-0.8\text{V}$, and $K_n=K_p$. (i) If $v_{O1}=0.6\text{V}$, determine v_{I1} and v_{O2} . (ii) Determine the range of v_{O2} for which both N_2 and P_2 are biased in the saturation region. (20%)
(b) What is the function realized at Y in the CMOS circuit shown in Fig.3(b)? (5%)
7. Your answers must be as brief as possible for the following questions
 - (a) List the parameters used to specify the transmission characteristics of a low-pass filter. (5%)
 - (b) A filter transfer function is written as the ratio of two polynomials. The degree of its denominator is P and the degree of its numerator is R. What's the order of the filter? (5%)
 - © For the filter in (b) to be stable, what is the relation between P and Q. (5%)
 - (d) For the amplifier in Fig. 4, what's the class of its output stage? (Hint: Maybe one of class AB, A, B, C, D, E, etc.) (5%)
 - (e) What is the function of the R and C_c in Fig. 4? (5%)

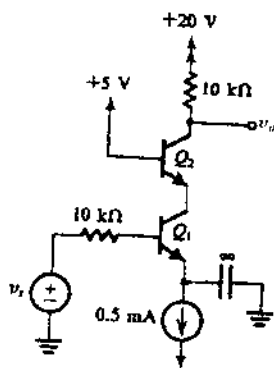

Fig. 1

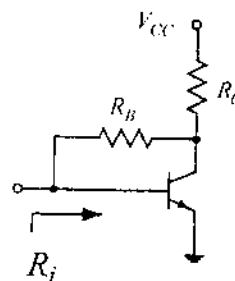

Fig. 2

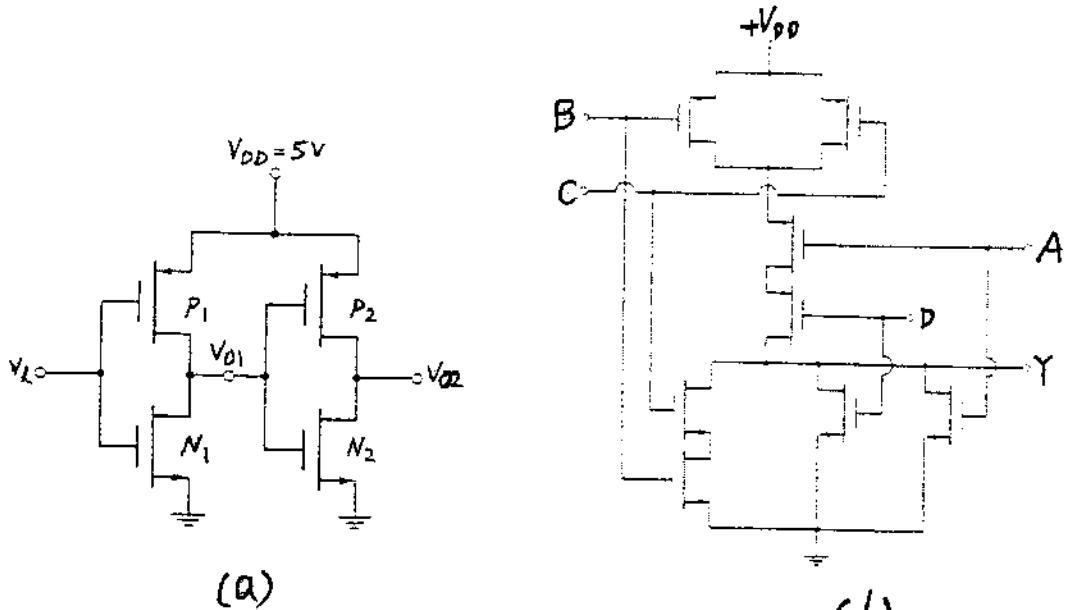

Fig. 3

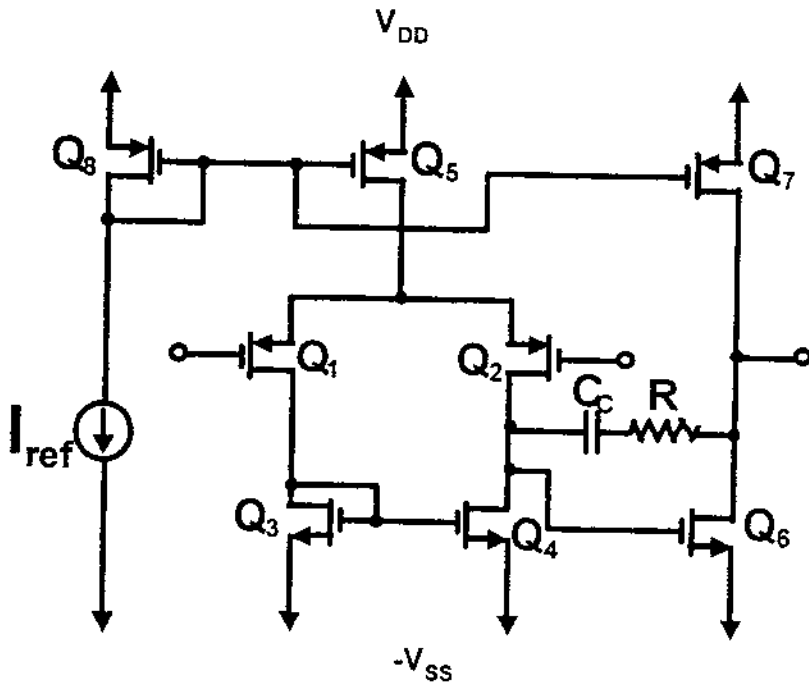

Fig. 4