

本試題是否可以使用計算機： 可使用， 不可使用（請命題老師勾選）

- Consider the circuit in Fig. 1. The transistor parameters are $V_{TN} = 1\text{ V}$ and $k_n' = 36\text{ }\mu\text{A}/\text{V}^2$. Determine the width-to-length ratio required in transistor M_2 such that $I_D = 0.5\text{ mA}$, $V_1 = 2\text{ V}$, and $V_2 = 5\text{ V}$. (10%)
- For the TTL circuit in Fig. 2, assume parameters of $\beta_F = 50$, $\beta_R = 0.1$, $V_{BE(\text{on})} = 0.7\text{ V}$, $V_{BE(\text{sat})} = 0.8\text{ V}$, and $V_{CE(\text{sat})} = 0.1\text{ V}$. Determine the power dissipated in the circuit (no load condition) for (a) $V_{\text{in}} = 0.1\text{ V}$ and (b) $V_{\text{in}} = 5\text{ V}$. (20%)

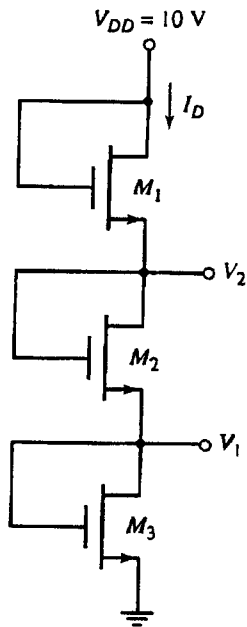

Fig. 1

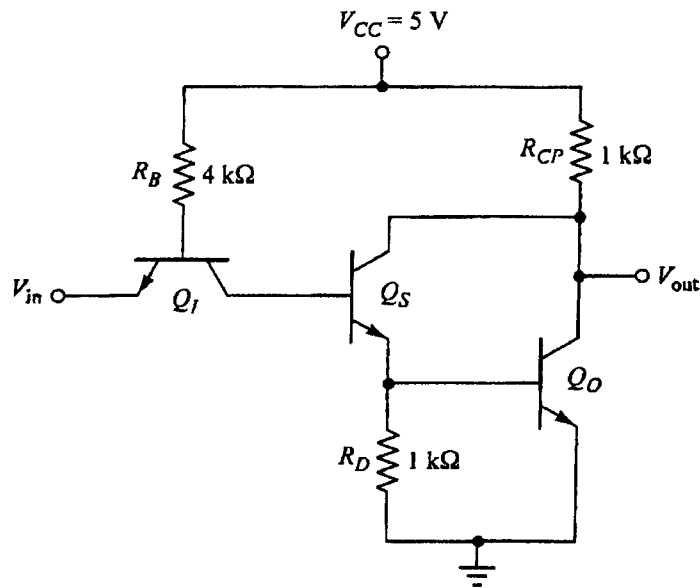

Fig. 2

- Why the current of a forward-biased p-n junction is an exponential function of the bias voltage? (5%)
 - Calculate the overall voltage gain of a common-source amplifier for which $g_m = 2.5\text{ mA}/\text{V}$, $r_o = 100\text{ k}\Omega$, and $R_G = 1000R_D = 10\text{ M}\Omega$. Assume the amplifier is fed from a signal source with a Thevenin resistance of $0.5\text{ M}\Omega$, and the amplifier output is coupled to a load resistance of $25\text{ k}\Omega$. (5%)
 - For the circuit shown in Fig. 3, draw the possible load line of the Schottky transistor and explain the advantage(s) of using such a Schottky transistor in this circuit. (10%)
- Assume $V_{CC} = 15\text{ V}$, $V_{BE} = 0.7\text{ V}$, $R_1 = 2R_2 = 100\text{ k}\Omega$, $\beta_{dc} (\equiv I_C/I_B) = 75$, and $R_C = 3R_E = 6\text{ k}\Omega$ for the circuit shown in Fig. 4, calculate V_{CE} and I_C . (10%)
 - Assume the circuit shown in Fig. 5 has matched BJTs, derive the small-signal input resistance R_i , output resistance R_o , and current gain $A_i (= i_o/i_i)$. (7%)

(背面仍有題目,請繼續作答)

本試題是否可以使用計算機： 可使用， 不可使用 (請命題老師勾選)

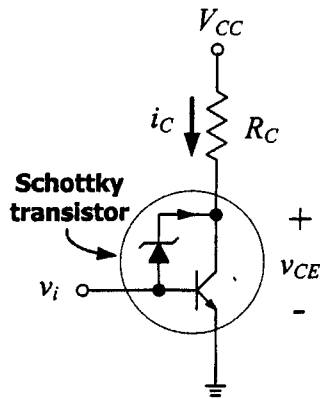

Fig. 3

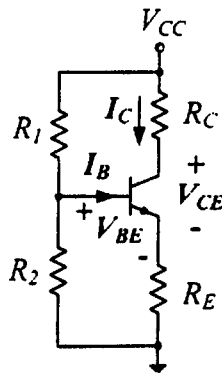

Fig. 4

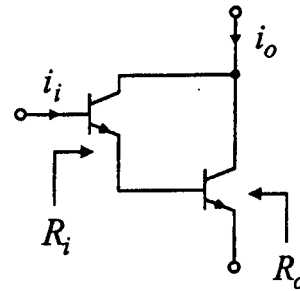

Fig.5

- We need an amplifier with a rise time of 300 ns. The amplifier we have has rise time of $3 \mu\text{s}$ and gain of 40. Find the resulting feedback factor β , if we correct the rise time problem with negative feedback. (5%)
- We have a nonfeedback amplifier with voltage gain of 920, $R_o = 3k\Omega$ and $R_i = 11k\Omega$. (a) Determine the class of feedback amplifier so that $R_{of} \leq 10\Omega$ and $R_y \geq 800k\Omega$. (4%) (b) Find the feedback factor β and closed-loop gain A_f of the feedback amplifier. (4%)
- Consider the circuit shown in Fig. 6, Let $R_1 = 2k\Omega$, $R_2 = 667\Omega$, $R_3 = 200k\Omega$, $C = 0.1\mu\text{F}$. Assume that op amp is ideal.
 - Find $\frac{V_o}{V_i}$ as a function of passive components R_1 , R_2 , R_3 and C. (8%)
 - Find the zeros and poles of this transfer function. (4%)
 - Plot the magnitude response of this transfer function. (8%) (Note: you have to show some numerical values at the important points on this plot to get the grade points).

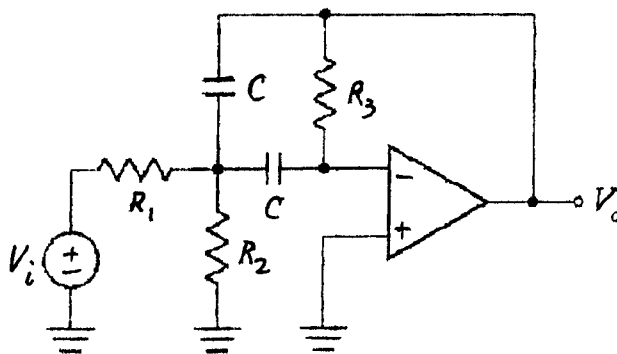

Fig. 6