

國立成功大學

112學年度碩士班招生考試試題

編 號： 69

系 所： 機械工程學系

科 目： 動力學及專業英文

日 期： 0206

節 次： 第 2 節

備 註： 可使用計算機

※ 考生請注意：本試題可使用計算機。請於答案卷(卡)作答，於本試題紙上作答者，不予計分。

1. [25%] The gear is defined as a toothed member designed to transmit motion to or receive motion from another toothed member, by means of successively engaged teeth. The two gears are rotatable around axes whose relative positions are fixed, forming a gear pair. The torque from the driving shaft to the driven one in a gear drive is transmitted due to the pressure of the teeth of the pinion on those of the wheel. To preserve a constant transmission ratio, the teeth of both pinion and wheel should have conjugate profiles. Parallel and co-planer shafts connected by gears are called spur gears. Spur gears have straight teeth and are parallel to the wheel's axis. The advantages of spur gears are their simplicity in design and economy of manufacture and maintenance. Spur gears are known as slow-speed gears. If noise is not a serious design problem, spur gears can be used at almost any speed. Helical gears have their teeth inclined to the axis of the shafts in the form of a helix. These gears are usually thought of as high-speed gears. Helical gears can take higher loads than similarly sized spur gears. The motion of helical gears is smoother and quieter than the motion of spur gears. Intersecting but co-planar shafts connected by gears are called bevel gears. Straight bevel gears can be used on shafts at any angle, but right angle is the most common. Bevel gears can be used to change the direction of drive in a gear system by 90 degrees.
- (1) Translate the first paragraph **into Chinese**.
- (2) Based on the information provided, **use your own words (in English)** to explain the differences between the three types of gears in terms of shaft arrangement, teeth meshing, and design considerations.
2. [25%] The double gear shown below rolls on the stationary lower rack; the velocity of its center A is 1.2 m/s directed to the right. Determine (a) the angular velocity of the gear, (b) the velocities of the upper rack R and of point D of the gear.

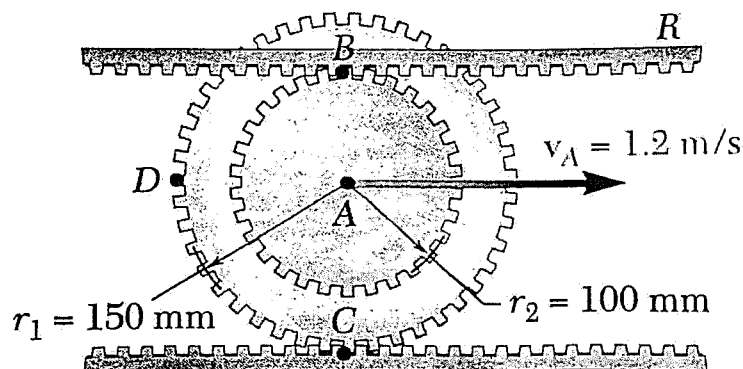

※ 考生請注意：本試題可使用計算機。 請於答案卷(卡)作答，於本試題紙上作答者，不予計分。

3. [25%] An industrial robot is being used to position a small part P . Calculate the magnitude of the acceleration \mathbf{a} of P for the instant when $\beta=30^\circ$ if $\dot{\beta}=10 \text{ deg/s}$ and $\ddot{\beta}=20 \text{ deg/s}^2$ at this same instant. The base of the robot is revolving at the constant rate $\omega=40 \text{ deg/s}$. During the motion arms AO and AP remain perpendicular.

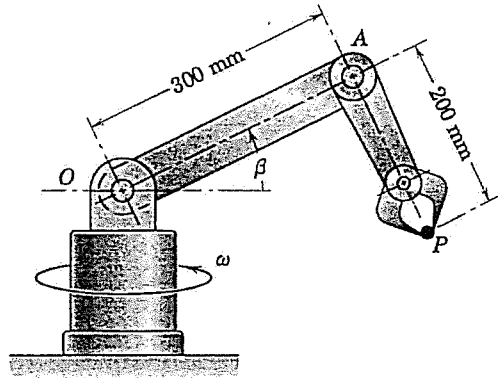

4. [25%] The uniform slender bar has a mass of 30 kg, a length of 1.2 m, and is released from rest in the near-vertical position shown, where the spring of stiffness 150 N/m is unstretched. Calculate the speed with which end A strikes the horizontal surface.

