

※ 考生請注意：本試題不可使用計算機。請於答案卷(卡)作答，於本試題紙上作答者，不予計分。

1. Draw a circuit of 6-bit D/A converter with an R-2R ladder network with the labeled V_{REF} , bit0 to bit5 of digital input, and V_O . (10%)
2. Consider an NMOS inverter circuit in Fig. 1 with $V_{DD} = 2.5V$ and $R_D = 20\text{ k}\Omega$, threshold voltage $V_{TN} = 0.5\text{ V}$ and conductance parameter $K_n = 0.3\text{ mA/V}^2$. Determine its input and output voltages at the transition point, minimum output voltage, maximum drain current, and maximum power dissipation. (20%)
3. A diode circuit shown in Fig. 2, determine the diode current I_D and diode voltage V_D for (a) $V_\gamma = 0.6\text{ V}$ and (b) $V_\gamma = 0.7\text{ V}$. (10%)
4. For the digital circuit as shown in Fig. 3, determine the Boolean expression for V_O in terms of the four input voltages $V_1, V_2, V_3,$ and V_4 with your truth table and detailed explanation. (10%)
5. For a common-gate circuit in Fig. 4, the NMOS transistor parameters are: threshold voltage $V_{TN} = 1\text{ V}$, conductance parameter $K_n = 3\text{ mA/V}^2$, and channel-length modulation parameter $\lambda = 0$. (a) Determine the quiescent current I_{DQ} and voltage V_{DSQ} . (b) Calculate the transconductance g_m and output resistance r_o . (c) Find the small-signal voltage gain A_v . (15%)
6. The transistor circuit in Fig. 5 has the parameters $\beta = 100, V_{BE(on)} = 0.7\text{ V}$, and $V_A = \infty$. Neglect the capacitance effects of the transistor. (a) Draw the three equivalent circuits that represent the amplifier in the low-frequency, midband range, and high-frequency range. (b) Sketch its Bode magnitude plot. (c) Determine the values of f_L and f_H . (15%)
7. Sketch a circuit of one-pole low-pass switched capacitor filter, and describe the methods to select the components values for meeting the specifications such that the low-frequency gain is -1 and the cutoff frequency is 1 kHz. (20%)

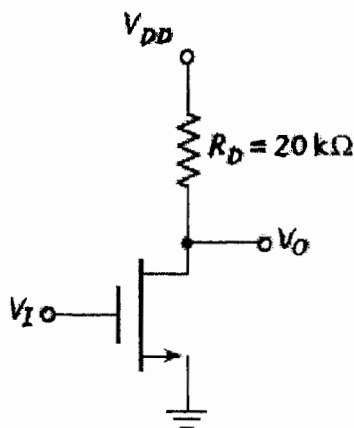

Fig. 1

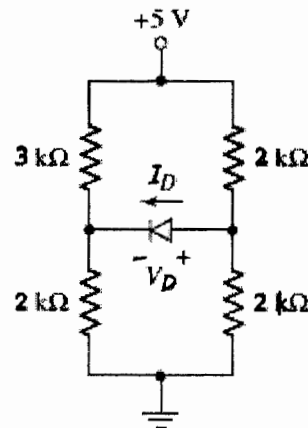

Fig. 2

(背面仍有題目,請繼續作答)

※ 考生請注意：本試題不可使用計算機。請於答案卷(卡)作答，於本試題紙上作答者，不予計分。

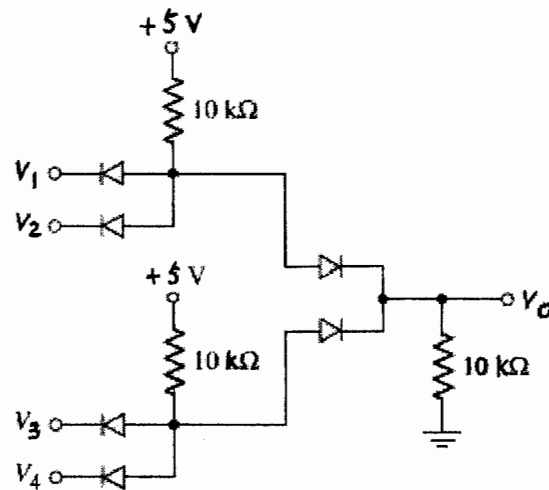

Fig. 3

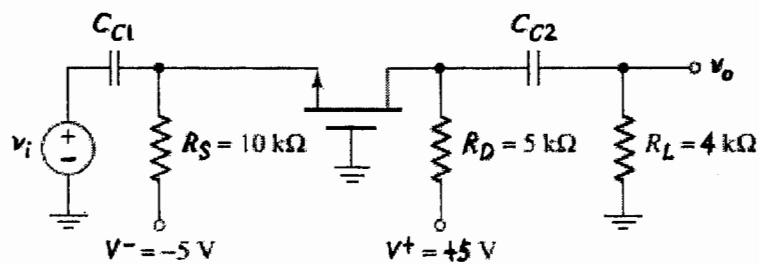

Fig. 4

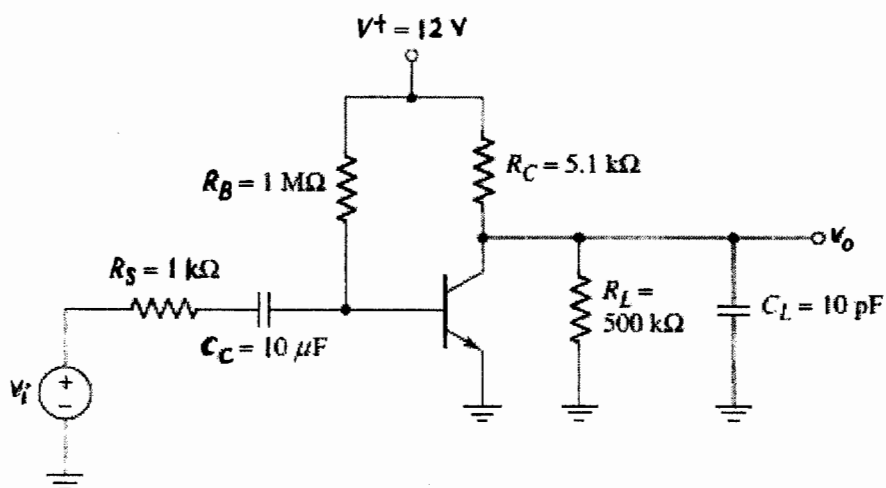

Fig. 5