

※ 考生請注意：本試題不可使用計算機。請於答案卷(卡)作答，於本試題紙上作答者，不予計分。

1. Given the following circuit. The necessary 2N7000 specifications are shown as follow. The BJT hfe is 100.
 (a) Draw the small signal model and the large signal model. (15%) (b) Find the **quiescent currents** of the two active devices and the voltage at point "M1G".(15%) (c) Given a 1KHz/0.5Volt sine wave as the input, find the amplitude at the point "Output". (10%) Show all details.

ON CHARACTERISTICS (Note 1)

Gate Threshold Voltage	($V_{DS} = V_{GS}, I_D = 1.0 \text{ mAdc}$)	$V_{GS(th)}$	0.8	3.0	Vdc
Static Drain-Source On-Resistance	($V_{GS} = 10 \text{ Vdc}, I_D = 0.5 \text{ Adc}$ ($V_{GS} = 4.5 \text{ Vdc}, I_D = 75 \text{ mAdc}$)	$r_{DS(on)}$	-	5.0 6.0	Ω
Drain-Source On-Voltage	($V_{GS} = 10 \text{ Vdc}, I_D = 0.5 \text{ Adc}$ ($V_{GS} = 4.5 \text{ Vdc}, I_D = 75 \text{ mAdc}$)	$V_{DS(on)}$	-	2.5 0.45	Vdc
On-State Drain Current	($V_{GS} = 4.5 \text{ Vdc}, V_{DS} = 10 \text{ Vdc}$)	$I_{d(on)}$	75	-	mAdc
Forward Transconductance	($V_{DS} = 10 \text{ Vdc}, I_D = 200 \text{ mAdc}$)	g_{fs}	100	-	μhos

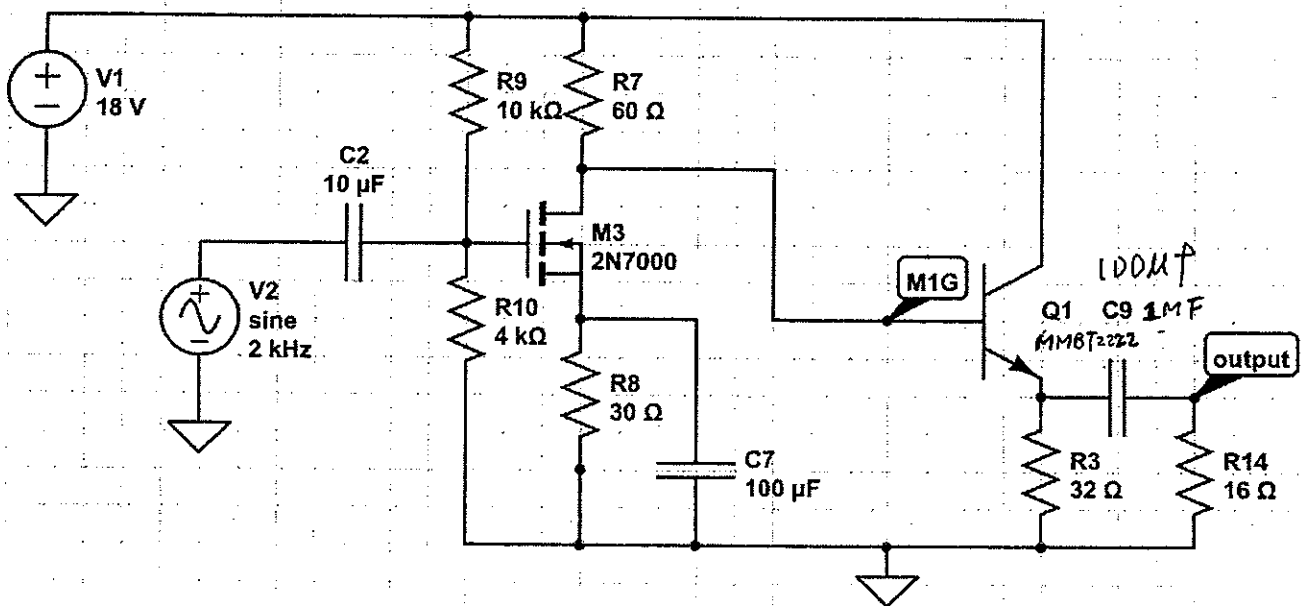
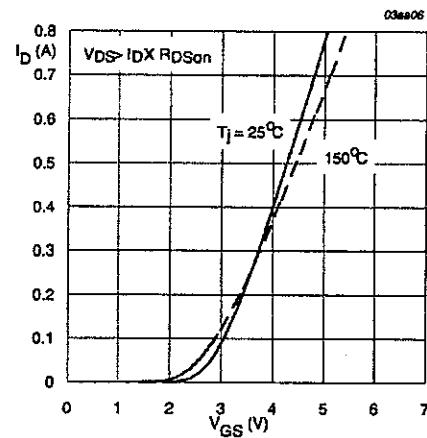
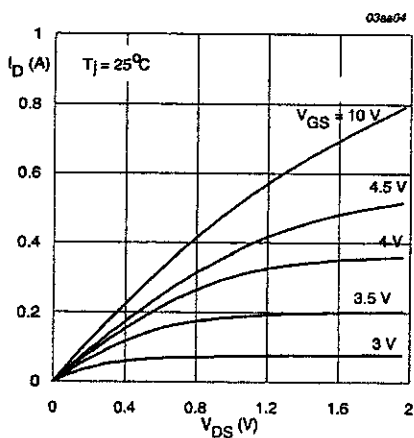

2. Given the following bandpass filter circuit. Give the magnitude frequency response in the range from 50Hz to 5KHz. (30%) Show all details.

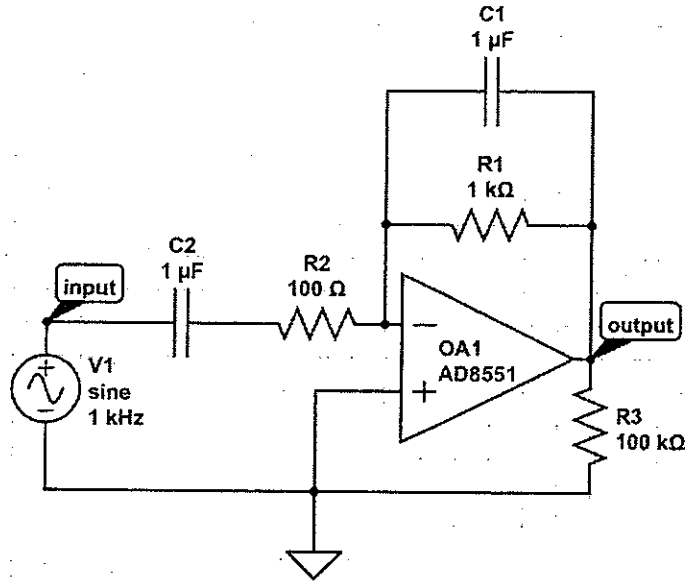

3. Given the following two circuits. The breakdown voltages of D4 and D5 are 3.3V and 6.8V in the second circuit, respectively. The input is a 4Volt/1KHz sine wave for both circuits. Draw the output waveforms of the two circuits separately. Show all details in how to obtain your answers. (30%)

