

臺灣綜合大學系統

106 學年度

轉學生聯合招生考試

試 題

類組：D09

科目名稱：動力學

科目代碼：D0994

臺灣綜合大學系統 106 學年度學士班轉學生聯合招生考試試題

科目名稱	動力學	類組代碼	D09
		科目碼	D0994

※本項考試依簡章規定各考科均「不可以」使用計算機

本科試題共計 2 頁

- (20%) A ball is thrown vertically upward from a point located 12 m above the ground. Knowing that it strikes the ground 3 s after release, determine (a) the speed with which the ball was thrown upward, (b) the speed with which the stone strikes the ground.
- (20%) The system shown is at rest when a constant 150 N force is applied to block *A*. Neglecting the masses of the pulleys and the effect of friction in the pulleys and between block *A* and the horizontal surface, determine (a) the velocity of block *B* after block *A* has moved 5 m, (b) the tension in the cable.
- (20%) A flywheel is rotating at a speed of 8000 rpm when the power is turned off. It is observed that the flywheel coasts to rest in 3 min. Assuming uniformly accelerated motion, determine (a) the angular acceleration, (b) the number of revolutions that the flywheel executes before coming to rest.
- (20%) A 25-kg cabinet is mounted on casters that allow it to slide on the rough floor ($\mu_k = 0.3$). If a 120 N force is applied as shown, determine (a) the acceleration of the cabinet, (b) the range of values of *h* for which the cabinet will not tip.
- (20%) A slender rod of length *l* and weight *W* is pivoted at one end as shown. It is released from rest in the position shown and swings freely. Determine the angular velocity of the rod as it passes through a vertical position and determine the corresponding reaction at the pivot.

背面有題，請繼續作答。

臺灣綜合大學系統 106 學年度學士班轉學生聯合招生考試試題

科目名稱	動力學	類組代碼	D09
		科目碼	D0994

※本項考試依簡章規定各考科均「不可以」使用計算機

本科試題共計 2 頁

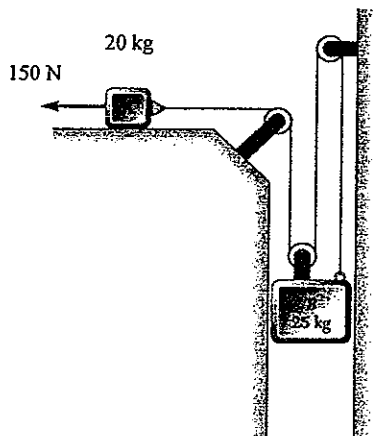

Problem 2.

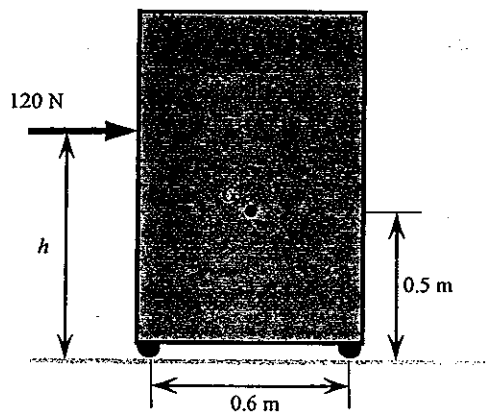

Problem 4.

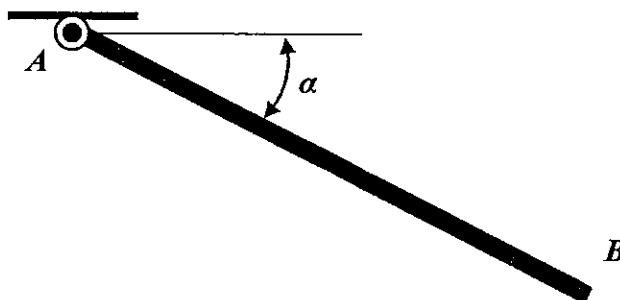

Problem 5.