

臺灣綜合大學系統

107 學年度 學士班

轉學生聯合招生考試

試 題

類組：D09

科目名稱：動力學

科目代碼：D0994

臺灣綜合大學系統 107 學年度學士班轉學生聯合招生考試試題

科目名稱	動力學	類組代碼	D09
		科目碼	D0994

※本項考試依簡章規定各考科均「不可以」使用計算機 本科試題共計 一 頁

- As rod OA rotates, pin P moves along the parabola BCD . Knowing that the equation of this parabola is $r = 2b / (1 + \cos \theta)$ and that $\theta = kt$, determine the velocity and acceleration of P when (a) $\theta = 0^\circ$, (b) $\theta = 90^\circ$. (25%)
- A 6-kg block B rests as shown on the upper surface of a 15 kg wedge A . Neglecting friction, determine immediately after the system is released from rest (a) the acceleration of A , (b) the acceleration of B relative to A . (Hint: $\sin 30^\circ = 0.5$, $\cos 30^\circ = 0.866$) (25%)
- Rod AB can slide freely along the floor and the inclined plane. Denoting by v_A the velocity of point A , derive an expression for (a) the angular velocity of the rod, (b) the velocity of end B . (25%)
- A beam AB of length L and mass m is supported by two cables as shown. If cable BD breaks, determine at that instant the tension in the remaining cable as a function of its initial angular orientation θ . (25%)

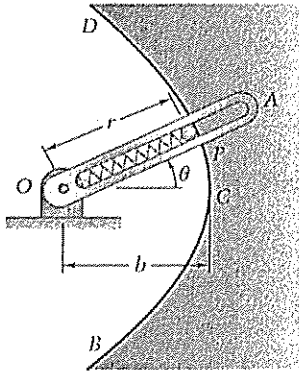

Fig. 1

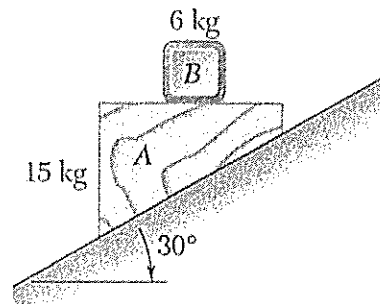

Fig. 2

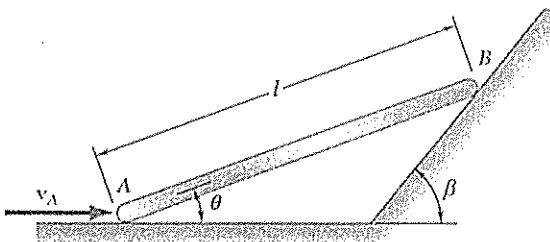

Fig. 3

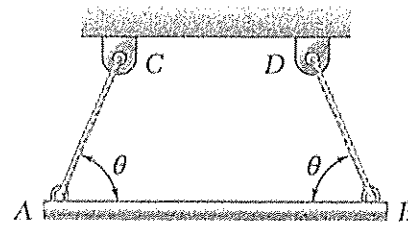

Fig. 4