

臺灣綜合大學系統

108 學年度 學士班
轉學生聯合招生考試

試 題

類組：D39

科目名稱：自動控制

科目代碼：D3992

臺灣綜合大學系統 108 學年度學士班轉學生聯合招生考試試題

科目名稱	自動控制	類組代碼	D39
		科目碼	D3992

※本項考試依簡章規定各考科均「不可以」使用計算機 本科試題共計 3 頁

1. For each of the following transfer functions: (a) Draw Poles-Zeros in the S-plane; (b) Find the natural frequency (ω_n) and damping ratio (ζ); (c) Roughly draw the time responses of these transfer functions based on the locations of Poles and Zeros; (15%)

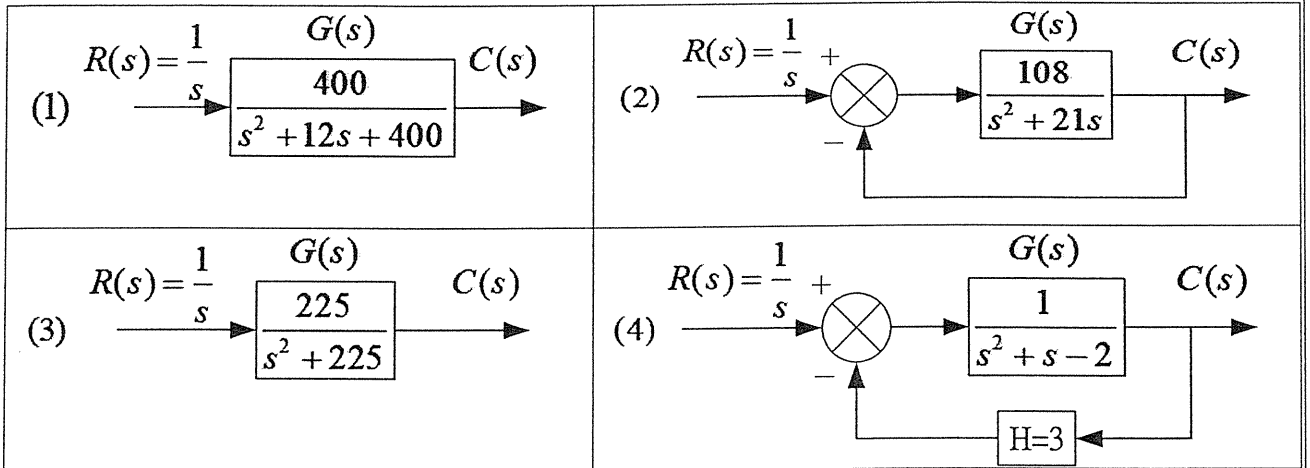

2. Please verify that how many roots of the following polynomial are in the right-half S plane, in the left-half S plane, and on the $j\omega$ -axis: (10%)

$$p(s) = s^5 + 6s^3 + 5s^2 + 8s + 10$$

3. Find out the range of K which stabilizes the system as shown in Figure 1. (15%)

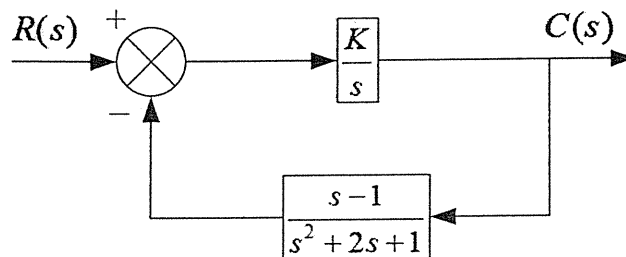

Figure 1

4. A feedback system is illustrated as Figure 2. Please calculate values of K_1 and K_2 which let the closed-loop system with a step input $R(s)$ satisfy the following two specifications: 1. Peak time $T_p = 0.8s$, and 2. Settling time $T_s = 1.5s$; (20%)

Hint: $T_p = \frac{\pi}{\omega_n \sqrt{1 - \zeta^2}}$; at $e_{ss} = \pm 2\%$, and $T_s = \frac{4}{\zeta \omega_n}$

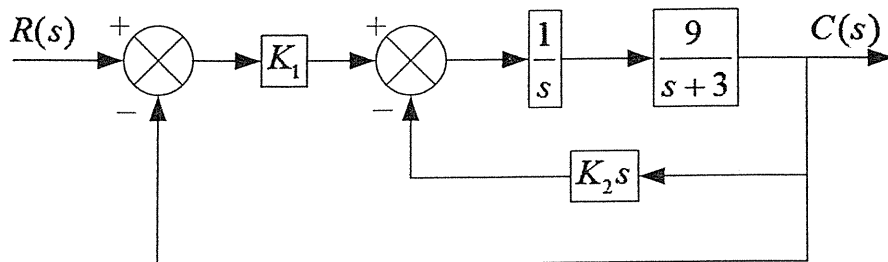

Figure 2

臺灣綜合大學系統 108 學年度學士班轉學生聯合招生考試試題

科目名稱	自動控制	類組代碼	D39
		科目碼	D3992

※本項考試依簡章規定各考科均「不可以」使用計算機 本科試題共計 3 頁

5. (a) $E(s)$ is the error function of this system and derive $E(s)$ as a function of $G(s)$ and $R(s)$.
 (b) If $R(s) = \frac{1}{s}$, and $G(s) = \frac{1}{s^2 + 3s + 1}$, please find e_{ss} .; (c) If $R(s) = \frac{1}{s}$, and $G(s) = \frac{1}{s^2 - 3s + 1}$, please find the steady state error e_{ss} . (15%)

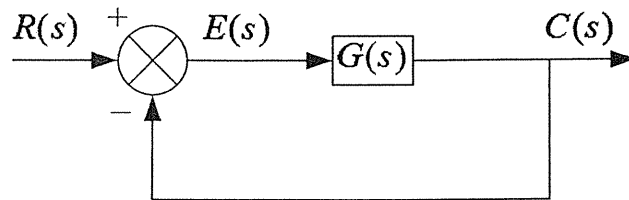

Figure 3

6. (a) Find the transfer function $(\frac{V_o(s)}{V_s(s)})$ of Figure 4.
 (b) Find damped ratio (ζ) and natural frequency (ω_n) of the transfer function in (a).
 (c) Based on the answers of (b), please calculate the following specifications: settling time (T_s), rising time (T_r), peak time (T_p) and maximum overshoot (%OS). When giving V_s as a unit step function, please find the steady state output ($\lim_{t \rightarrow \infty} v_o(t)$). (15%)

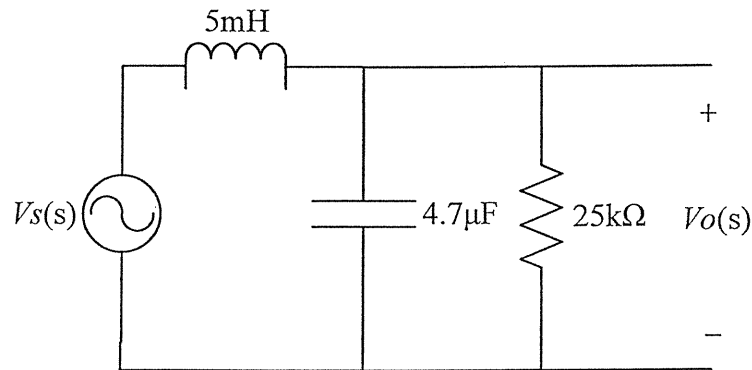

Figure 4

Hint : Impedance of inductor is sL

Impedance of conductor is $\frac{1}{sC}$

$$T_r \cong \frac{1.8}{\omega_n} \cdot \lim_{t \rightarrow \infty} v_o(t) = \lim_{s \rightarrow 0} sV_o(s) \cdot \%OS = e^{(-\zeta\pi/\sqrt{1-\zeta^2})} \times 100$$

臺灣綜合大學系統 108 學年度學士班轉學生聯合招生考試試題

科目名稱	自動控制	類組代碼	D39
		科目碼	D3992

※本項考試依簡章規定各考科均「不可以」使用計算機

本科試題共計 3 頁

7. Consider the following system

$$\dot{X} = \begin{bmatrix} 1 & 2 & 3 \\ 0 & 1 & -1 \\ 2 & 0 & 0 \end{bmatrix} X + \begin{bmatrix} 1 \\ 0 \\ 0 \end{bmatrix} u$$

$$y = [3 \quad 1 \quad 2] X$$

Design a state feedback controller such that the desired closed-loop poles are at -1, -2 and -3. (10%)